



Fluidsentry™
Monitored Valves

MONITORED HYDRAULIC VALVE SYSTEMS

'HBV' Cetop Series.



**WORKSAFE VICTORIA AWARDS
BEST RISK SOLUTION
2005**

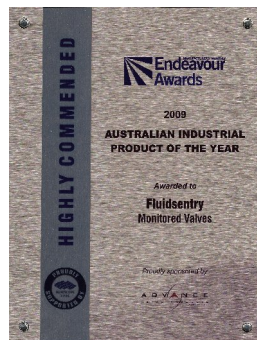

SAFE WORK AUSTRALIA AWARDS 2005

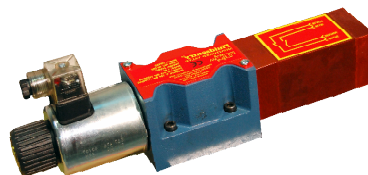
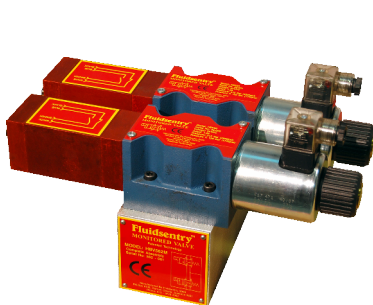

Patented Technology

SUITABLE FOR RISK CATEGORY 4 APPLICATIONS

As per EN 954-1 & AS4024.1

SIL as per IEC 61508 & EN ISO 13849

Fluidsentry Pty Ltd
P.O.Box 8135
(1 / 32-34 Frankston Gardens Drive)
Carrum Downs Victoria 3201 Australia
Ph: +61 (3) 9776 4352 - Fax: +61 (3) 9776 4372
e-mail: sales@fluidsentry.com
www.fluidsentry.com

SYSTEM OVERVIEW

PURPOSE

The valve monitoring system is primarily designed as an interface between the fluid power operation of a machine and the electrical safety circuits monitoring gates, guard and emergency stop circuits. The monitoring function can provide for detection of a single valve fault including change of switching times, sticking valve or spontaneous change of state as per the requirements of Australian Standard AS4024.1 Safety of Machinery, Part 1501 Design of safety related parts of control systems – General principles and European Standard EN954-1 Safety of Machinery – Safety related parts of control systems. The systems are additionally suited to the monitoring requirements of machine specific standards such as AS1219 Power Presses-Safety Requirements, EN693 Safety of Hydraulic Presses and EN692 Mechanical Presses.

HYDRAULIC SYSTEM

The Hydraulic system comprises two Cetop 3 or Cetop 5 Eaton valves with a spool configuration selected as determined by a hazard identification / risk assessment for each and every application.

The operation of the monitoring will now permit hydraulic power pack motors and pumps to remain online during operator access in to machinery areas which would have previously required full current isolation.

The following installation guidelines would require the pump to be pressure compensated type or a relief / unloading valve fitted directly on pump outlet.

INSTALLATION

The dual valve system has been designed to interface with new or existing hydraulic applications and can be fully interlocked in to any existing safety systems to a category 4 level of integrity.

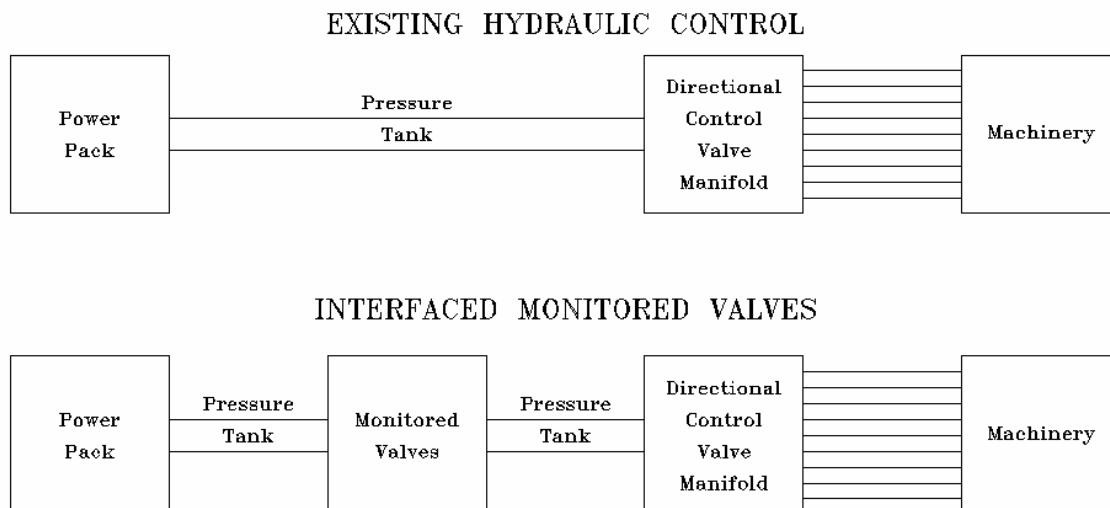

Fluidsentry™

HYDRAULIC VALVE SPECIFICATIONS

Description:	Dual directional control valves mounted on a specially manufactured manifold for hydraulic safety applications in Cetop 3 or Cetop 5 sizes supplied in a four port two position single solenoid format. The valve incorporates a two pole precision positive driven plunger type limit switch pre approved to category 4 safety applications.	
Materials:	Main body, extension housing and end cap: Spool:	Steel and Aluminium Induction Hardened Steel
	Pushrod Return spring: Spool Return Spring: Screws:	Steel Steel Cap Screws
Switch:	Make: Model: Type: Approvals: Contacts:	Bernstein GC-U1Z iw Precision Limit Plunger EN 60947-5-1, EN 60947-1, 73/23/EEC 1 x Normally closed 1 x Normally Open
Wiring:	Switch Contacts NC: Spare Contacts NO:	11 – 12 White – Black 23 – 24 Brown – blue
Lead:	Type:	Polyurethane Oil Resistant
Coil:	Voltages available: Current/Watts	24VDC Cetop 3 1.25 Amp/30Watts Cetop 5 1.625 Amp/39 Watts
Performance:	Valve working pressure range: Solenoid: Port connection: P, T, T1, A, B Medium: Oil Operating temperature range: Flow Rate Activation time: Deactivation time:	0 – 350 Bar – Cetop 3 0 – 315 Bar – Cetop 5 Direct Acting ¾" BSP Parallel Hydraulic Oil ISO 32 to 68 -20 C to +70 C (Mineral Oil) Subject To Spool Selection Cetop 3 32 Milliseconds Cetop 5 50 Milliseconds Cetop 3 50 Milliseconds Cetop 5 130 Milliseconds
Rating:	Protection:	IP 65
Weight:	Cetop 3 Dual valve on manifold: Cetop 5 Dual valve on manifold:	7 kg 13 kg
Manual:	Manual Override:	Removed
Cleanliness:	ISO 4406 Code	19/16/13

EN ISO 13849 Data Sheet

Valve Type	HBV-36, HBV-362M, HBV-56, HBV-562M
Date	April 2011
Revision	A
MTTFd	150 years
Vibration	Vibration in line with spool axis < 5g
Silting	Silting occurs when hydraulic valves are left in the actuated position for long periods of time. It is recommended that the user considers periodically cycling the valve to limit these effects.

Note

The products must be used in accordance with the installation instructions and operating conditions in the relevant data sheet, which has been produced to support the requirements of the harmonized standard EN ISO 13849.

Additionally, for products intended to be sold in European Economic Area:

“Safety devices” or other safety functions mentioned in any product literature are not necessarily “safety components” as defined by the Machinery Directive 2006/42/EC, unless otherwise stated together with the CE Mark and specific reference to said directive.



DECLARATION OF CONFORMITY

Valves modified by Fluidsentry Pty Ltd to the specifications to conform to the requirements of the following Directives and European Standards.

Low Voltage Directive: 73/23/EEC – EN 60204, IEC 1010, IEC 950.

EMC Directive: 89/336/EEC – EN 55014, EN 50081-2, EN 50082-1, EN 50082-2

Machinery Directive: 98/37/EC – EN 292-1, EN 292-2, EN 982, EN 954-1, EN 1050.

Fluidsentry Pty Ltd herewith declares that the supplied Fluidsentry™ models of:

VALVES: HBV Series

TYPE: HYDRAULIC

Comply with all applicable Directives and Harmonized Standards for Hydraulic Fluid Power Systems and their components and are qualified to bear the CE mark. Melbourne Australia – 27th May 2008

Valve 1 Serial No:

Valve 2 Serial No:

Manifold Serial No:

Test Date:/...../.....

FLUIDSENTRY™
ACN 109 094 975
P.O. Box 8135
Carrum Downs Vic 3201.
AUSTRALIA.
Phone: +61 (0)3 9776 4352
Fax: +61 (0)3 9776 4372
Email: sales@fluidsentry.com

Murray Andrew Hodges

Name and signature of
Authorized person.

ELECTRICAL INTERFACING /INTERLOCKING

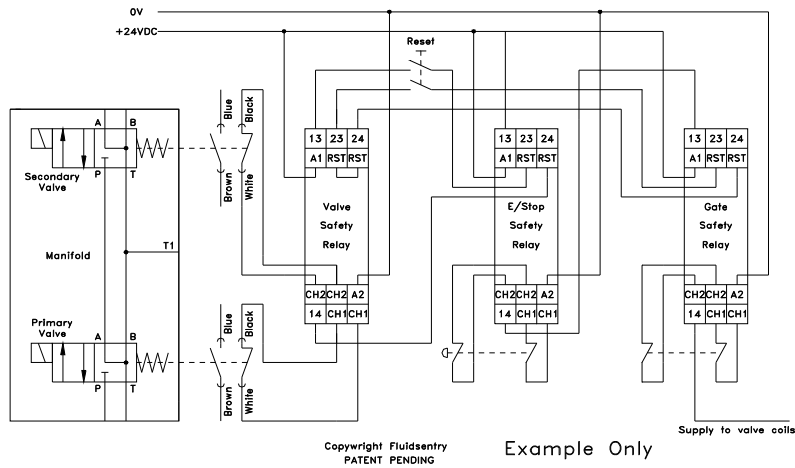

MANIFOLD

Cetop 3: HBV362M
Cetop 5: HBV562M

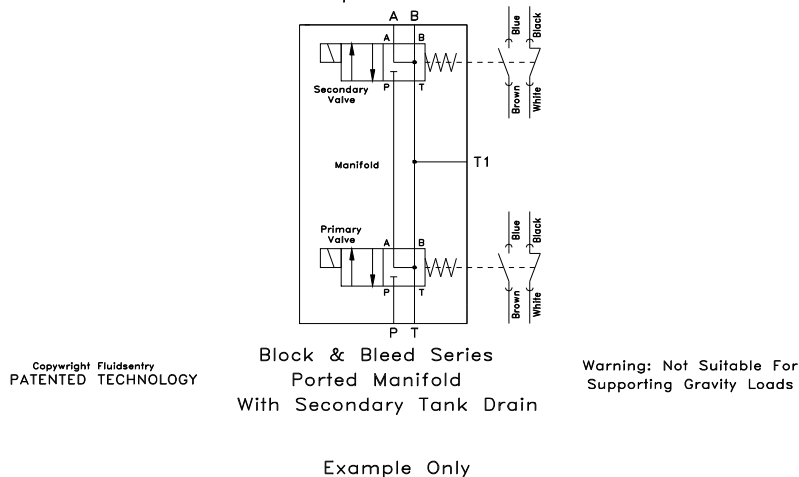

CAUTION – IMPORTANT: The above drawings are a conceptual example and are intended for guidance purposes only. They have not been specifically drawn in relation to your plant. Failing to ensure professional installation of Fluidsentry equipment which has regard to the specific circuit design and operation of the plant on which it is being installed may create a safety hazard. Accordingly Fluidsentry is not liable for any loss or injury, whether direct or indirect, resulting from the incorrect installation of this product.

DELTA "P" CURVES

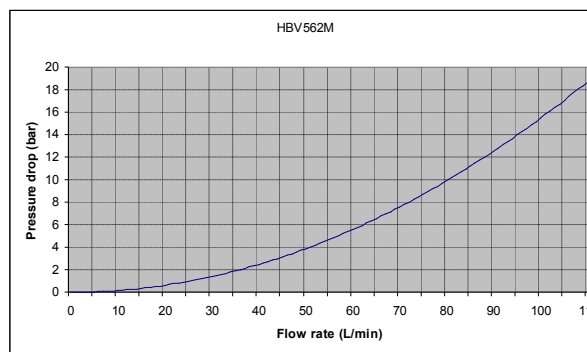
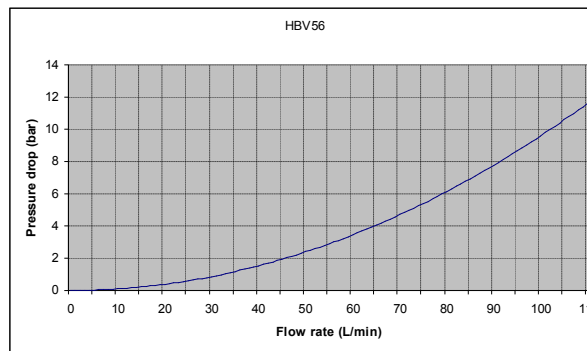
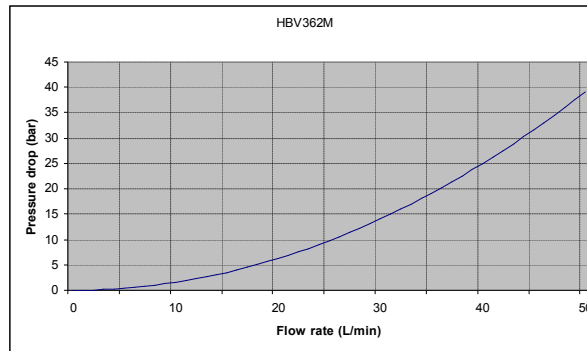
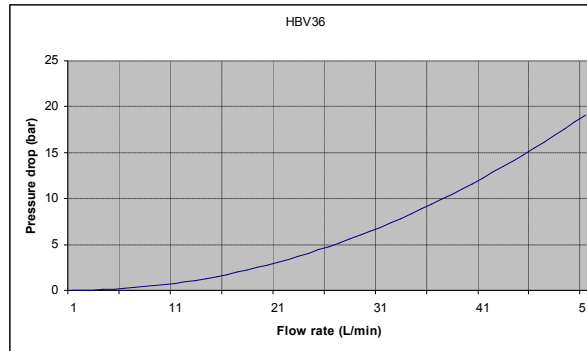

CORRECT USAGE

Circuit Placement and Connection

Careful consideration must be given to suitable circuit placement and care must be taken not to pressurise the tank port of the monitored valve. Pressurisation of the tank ports can cause damage to the valve. Outlet ports of control valving must not be connected the 'T' port of the monitored valves. For example where a monitored block and bleed function is to be performed in conjunction with a directional control valve (DCV), the monitored valve would be typically placed in circuit prior to the DCV. The 'T' or tank ports must be plumbed directly to tank without any other interconnection or restriction.

Cleanliness

Fluidsentry recommends 10 micron absolute filtering for the hydraulic supply to monitored valving.

Connection of Tank Lines

Return line filtering must not be used on 'T' or 'T1' tank lines.

Silting

Silting occurs when hydraulic valves are left in the actuated position for long periods of time and in conjunction with dirty or contaminated oil this can cause valves to seize in a dangerous state. The only remedy for such a situation is maintained oil filtering systems and periodic operation of valves. Valves should be cycled a minimum once every 8 hours of continual operation. Silting may also be overcome by cycling each valve at some idle time when there is no requirement for access by operators and there is no operation of the hydraulics.

Power Supply

A power supply providing the total current consumption of each coil energised at any one time is required. If an inadequate power supply exists, valves may fail to energise and solenoid coils could be subject to damage.

Cooling

The solenoid coils of the HBV series monitored valves are cooled via recirculation of the hydraulic oil. Solenoid coils should not be energised for an extended period without an active hydraulic oil flow.

Gravity Loads

Due to spool seepage and or drainage orifices where applied, monitored spool valves are not recommended for gravity loads.

Monitoring

Each Fluidsentry monitored valve provides a normally closed mechanically linked positive opening high precision switch for the safety function (de-energised state). To prevent undetected faults the monitoring contacts should not be series connected in a feedback circuit. For safety applications the normally closed contacts must be connected to individual electrical safety monitoring system inputs. Each valve has an additional normally open contact for process control signaling purposes.

CETOP 3 VALVE & MANIFOLD DIMENSIONS

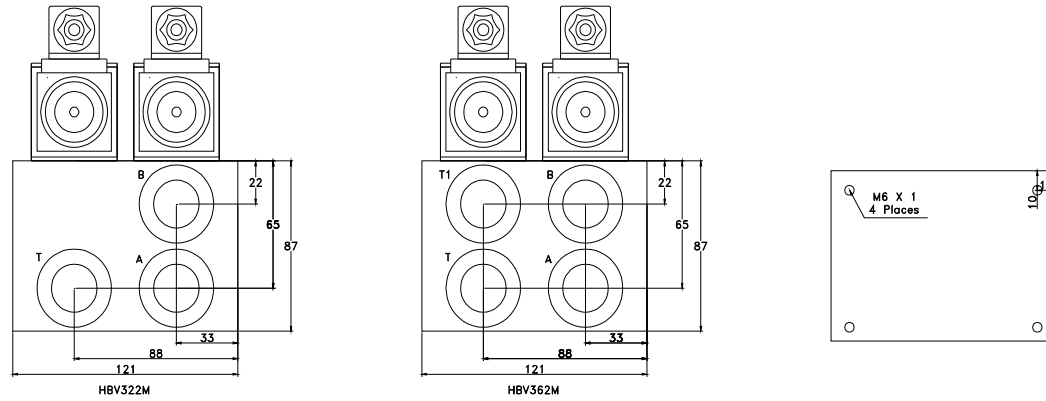

Note: All Ports 3/4" BSP Parallel

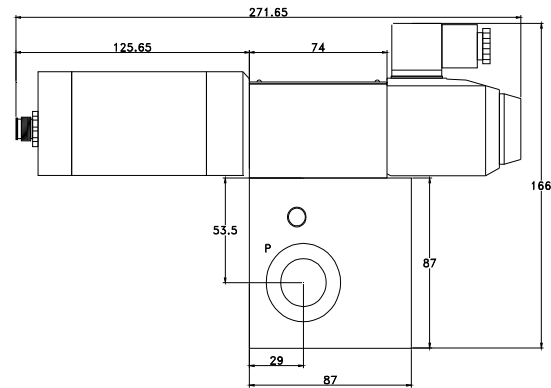

CETOP 5 VALVE & MANIFOLD DIMENSIONS

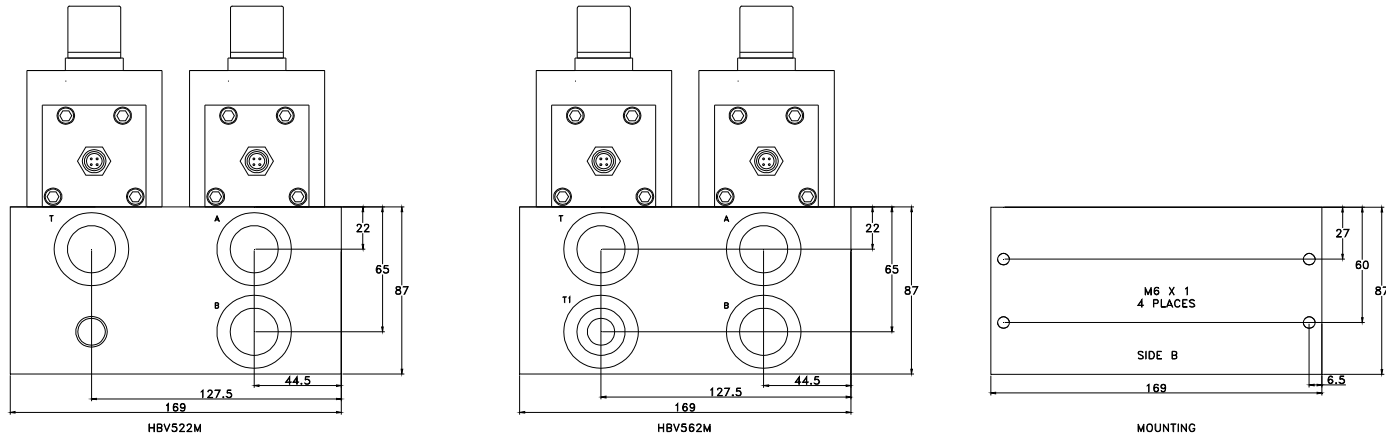

Note: ALL PORTS 3/4" BSR PARELLEL

