

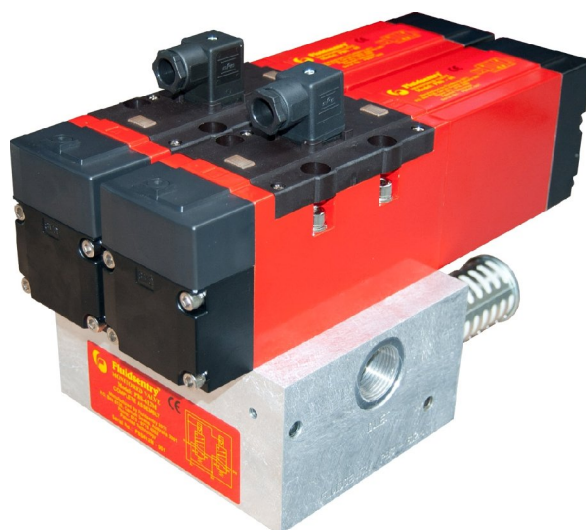

Fluidsentry™
Monitored Valves

1" Monitored Pneumatic Valves On Series Ported Manifold

Patented Technology



SUITABLE FOR RISK CATEGORY 4 APPLICATIONS

As per EN 954-1 & AS4024.1

SIL 3 as per IEC 61508 & EN ISO 13849-1

Applications Include:

Pneumatic Presses

Pneumatic Guillotines

Automated Fixtures

Palletising Equipment

Packaging Machinery

Robot & Automated Cells

Pneumatic Pushers & Ejectors

Guard Access Preconditions

Pneumatic Strapping Machines

Fluidsentry Pty Ltd

PO Box 8135

(1 / 32-34 Frankston Gardens Drive)

Carrum Downs Victoria 3201 Australia

Ph: +61 (0) 3 9776 4352 - Fax: +61 (0) 3 9776 4372

E-mail: sales@fluidsentry.com

www.fluidsentry.com

Fluidsentry™

VALVE SPECIFICATIONS

Description:	Directional control valves for pneumatic safety applications in five port two position sliding spool type with static seals, mounted on a safety manifold configured for three port two position operation. Each valve incorporates a two-pole positive opening plunger type switch with positive opening contact. The two models offered have certification to meet Australian & European machinery safety standards. Valves are supplied with 24VDC solenoid coils as standard unless otherwise specified.	
Model:	Dual series ported manifold valves	PBS-612M (Suitable for Risk Category 4 applications)
Materials:	Main body, extension housing: Pilot housing: Spool: Return spring: Seals: Screws: Lubricant:	Aluminium Plastic Aluminium Steel Nitrile rubber Cap Screws Diamond Grease
Switch:	Make: Model: Type: Approvals: Contacts:	Bernstein 188-U1Z w (608.6103.008) Plunger EN 1088, EN 60947-5-1, EN 292, EN 60204-1 1 x Normally Closed (Safety Contact) 1 x Normally Open (Non Safe Contact)
Wiring:	Switch Terminals:	11 - 12 White – Black (NC), 21 - 22 Brown – blue (NO)
Coil:	Voltages available: Power Consumption DC: Features: Allowable Voltage: Apparent Power:	240vac, 110vac, 24vac, 24vdc, 12vdc 1.8W Indicator light and surge suppression -15% to + 10% Rated Voltage Inrush: 5.6VA / 50Hz 5.0VA / 60Hz Holding: 3.4VA (2.1W) 50Hz, 2.3VA (1.5W) 60Hz
Plug Wiring:	Pin 1: Pin 3: Earth:	Positive / Active Negative / Neutral Earth
Performance:	Valve working pressure range: Port connection: Medium: Operating temperature range: Cv (flow factor) Maximum Operating Frequency: Activation time: Deactivation time:	250 – 1000 kPa 1" BSPP Compressed air filtered to 5 micron and/or lubricated Max +50 Celsius P to A 8.2 2Hz 35 Milliseconds 140 Milliseconds
Rating:	Protection:	IP 62
Approvals:	Low Voltage Directive: EMC Directive: Machinery Directives:	File No: R 9250033 File No: H/EMC 95000251-3 98/37/EC – EN 292-1, EN 292-2, EN 983, EN 954-1, EN 1050
Manual:	Manual Override:	Disabled Internally
Silencers:	Pilot Exhaust: Main Exhaust: Switch Body Vent	1/8" BSP SMC Part No: AN101-01 1" BSP SMC Part No: AN600-10 1/8" BSP Button Silencer

Electrical Interlocking/Interfacing

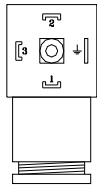

Plug Connection
 Pin 1: Positive / Active
 Pin 3: Negative / Neutral

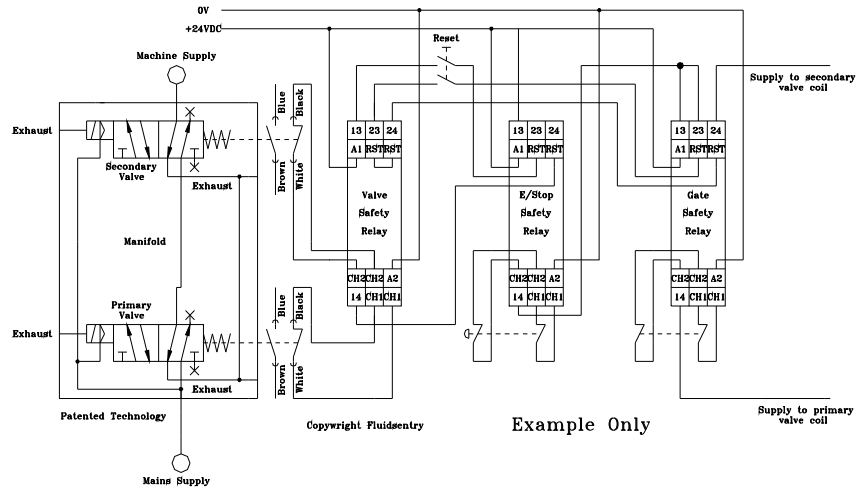

Model Shown PBS-412M

Pneumatic Connection

Suitable For Risk Category 3 & 4

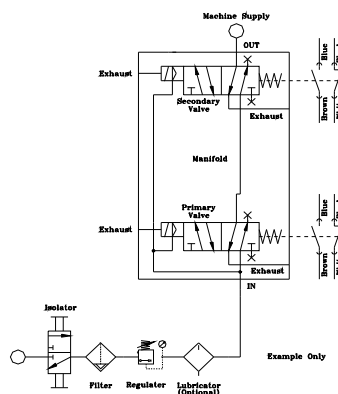

Model PBS-612M

CAUTION – IMPORTANT: The above drawings are a conceptual example and are intended for guidance purposes only. They have not been specifically drawn in relation to your plant. Failing to ensure professional installation of Fluidsentry equipment which has regard to the specific circuit design and operation of the plant on which it is being installed may create a safety hazard. Accordingly Fluidsentry is not liable for loss or injury, whether direct or indirect, resulting from the incorrect installation of this product.



Fluidsentry[™]
Monitored Valves

EN ISO 13849 Data Sheet

Valve Type	PBS-612M
Date	April 2011
Revision	A
MTTFd	30 years
Vibration	Vibration in line with spool axis < 5g

Note

The products must be used in accordance with the installation instructions and operating conditions in the relevant data sheet, which has been produced to support the requirements of the harmonized standard EN ISO 13849.

Additionally, for products intended to be sold in European Economic Area:

“Safety devices” or other safety functions mentioned in any product literature are not necessarily “safety components” as defined by the Machinery Directive 2006/42/EC, unless otherwise stated together with the CE Mark and specific reference to said directive.



DECLARATION OF CONFORMITY

For Safety Components in accordance with Annex IIC (Machinery Directive)

Valves manufactured by FLUIDSENTRY Pty Ltd conform to the requirements of the following Directives and European Standards.

Low Voltage Directive: 73/23/EEC – EN 60204, IEC 1010, IEC 950.

EMC Directive: 89/336/EEC – EN 55014, EN 50081-2, EN 50082-1, EN 50082-2

Machinery Directive: 98/37/EC – EN 292-1, EN 292-2, EN 983, EN 954-1, EN 1050, EN60204.

Fluidsentry herewith declares that the supplied Fluidsentry™ models of:

VALVES: MODELS PBS-612M (Dual Valve System)

TYPE: DUAL MONITORED PNEUMATIC VALVES
MOUNTED ON A SERIES PORTED MANIFOLD

Comply with all applicable Directives and Harmonized Standards for Pneumatic Fluid Power Systems and their components and are qualified to bear the CE mark . Melbourne Australia 3rd April 2011 .

FLUIDSENTRY™
ACN 109 094 975
P.O.Box 8135
Carrum Downs Vic 3201
AUSTRALIA.
Phone:+61 (0)3 9776 4352
Fax:+61 (0)3 9776 4372
Email: sales@fluidsentry.com

Murray Andrew Hodges

Name and signature of
Authorized person.

Valve Serial No.

Valve Serial No.

Manifold Serial No.

Tested/...../.....

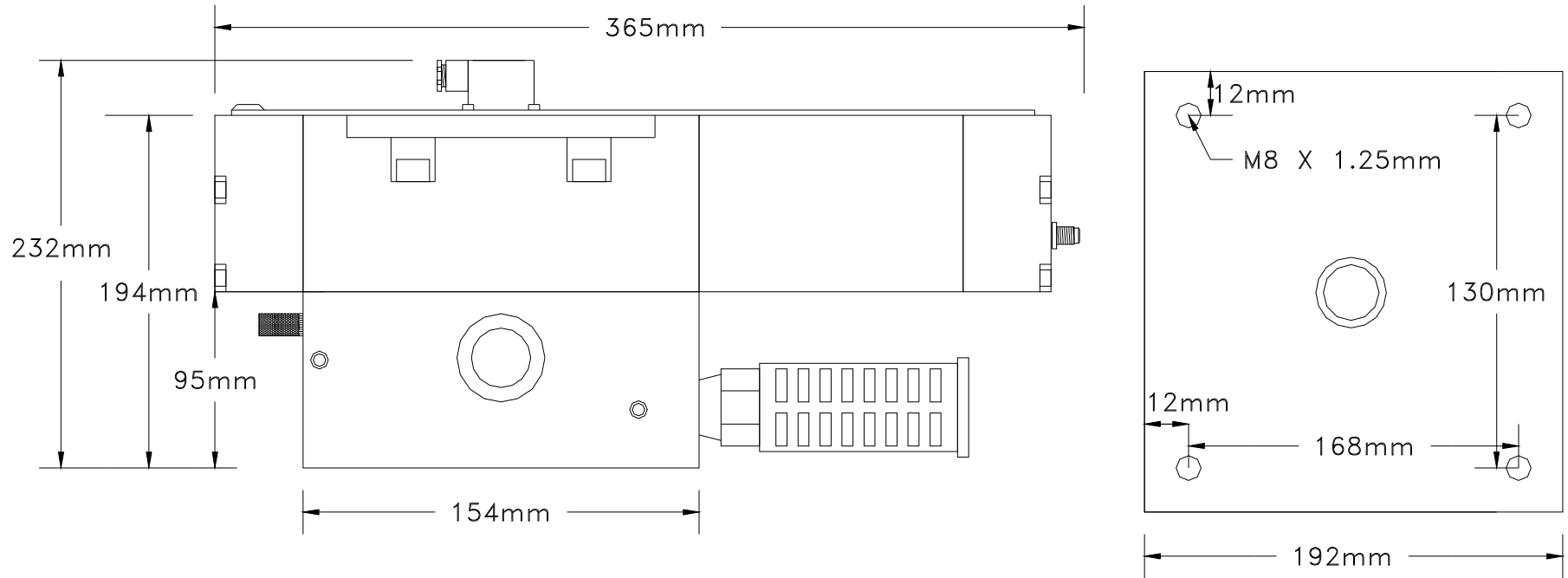



PBS-612M Dual Valve System Dimensions

Safety Instructions



These safety instructions are general in nature, and intended to prevent hazardous situations and/or equipment damage. These instructions indicate the level of potential hazard by labeling 'Caution' 'Warning' or 'Danger'. To ensure safety, be sure to observe ISO4414 Note 1, JIS B 8370 Note 2 and other safety practices.

The person who designs the pneumatic system or decides its specification must also refer to the specific Safety Instructions supplied for individual components which can be found in each Product Series brochure.

	Caution:	Operator error could result in injury or equipment damage.
	Warning:	Operator error could result in serious injury or loss of life.
	Danger:	In extreme conditions, there is a possibility of serious injury or loss of life.



Warning

1. **The compatibility of pneumatic equipment is the responsibility of the person who designs the pneumatic system or decides its specifications.**

Since the products specified here are used in various operating conditions, their compatibility with the specific pneumatic system must be based on specifications or after analysis and/or tests to meet your specific requirements.

2. **Only trained personnel should operate pneumatically operated machinery and equipment.**

Compressed air can be dangerous if an operator is unfamiliar with it. Assembly, handling or repair of pneumatic systems should be performed by trained and experienced operators.

3. **Do not service machinery/equipment or attempt to remove components until safety is confirmed.**

1. Inspection and maintenance of machinery/equipment should only be performed after confirmation of safe locked-out control positions.
2. When equipment is to be removed, confirm the safety process as mentioned above. Cut the supply pressure for the equipment and exhaust all residual compressed air in the system.
3. Before machinery/equipment is re-started, take measures to prevent quick extensions of the cylinder piston rod etc. (Bleed air into the system gradually to create back pressure)

4. **Contact Fluidsentry if the product is to be used in any of the following conditions:**

1. Conditions and environments beyond the given specifications, or if product is used outdoors.
2. An application which has the possibility of having negative effects on people, property, or animals, requiring special safety analysis.

Note 1) ISO4414: Pneumatic fluid power – Recommendations for the application of equipment to transmission and control systems.

Note 2) JIS B 8370: Pneumatic systems axiom.

Precautions



Selection Warning

1. Confirm specifications

Products represented in this catalogue are designed for use in compressed air applications only, unless otherwise indicated. Do not use the products outside their design parameters.

Installation Warning

1. Do not install unless the safety instructions have been read and understood.

Keep this catalogue on file for future reference.

2. Maintenance

When installing the products, please allow access for maintenance.

3. Tightening Torque

When installing the products, please follow the listed torque specifications

Piping Caution

1. Before Piping

Make sure that all debris, cutting oil, dust, etc. are removed from the piping.

2. Sealant Tape

When installing piping or fitting into a port, ensure that sealant material does not clog up the pressure port. When using sealant tape, leave the first 1.5 to 2 thread turns exposed at the end of the pipe/fitting.

Air Supply Warning

1. Operation fluid

Compressed Air

2. Install an air dryer, aftercooler etc.

Excessive condensate in a compressed air system may cause valves and other pneumatic equipment to malfunction. Installation of an air dryer, after cooler, etc. is recommended.

3. Drain

If condensate in the drain bowl is not emptied on a regular basis, the bowl will overflow and allow the condensate to enter the compressed air lines. If the drain is difficult to check and remove, it is recommended that a drain bowl with the autodrain option be installed.

4. Use clean air

If the compressed air supply is contaminated with chemicals, synthetic materials, corrosive gas, etc., damage to the pneumatic equipment may occur.

Environment Warning

1. **Do not use in an environment where the product is directly exposed to corrosive gases, chemicals, salt water, water or steam.**
2. **Do not expose the product to direct sunlight for an extended period of time. If the product has to be mounted in an area where exposure to direct sunlight cannot be avoided, the use of a protective cover is recommended.**
3. **Do not mount the product in a location where it is subject to strong vibrations and/or shock.**
4. **Do not mount the product in a location where it is exposed to radiant heat**

Maintenance Warning

1. Maintenance

If handled improperly, compressed air can be dangerous. Assembly, handling and repair of pneumatic systems should be performed by qualified personnel only.

2. Drain

Remove condensate from the filter bowl on a regular basis.

3. Shut-down before maintenance

Before attempting any kind of maintenance make sure the supply pressure is shut off and all residual air pressure is released from the system to be worked on.

4. Start-up after maintenance

Apply operating pressure and power to the equipment and check for proper operation and possible air leaks. If operation is abnormal, please verify product set-up parameters.

5. Do not make any modification to the product

Do not take the product apart